

**Thermo Scientific TSQ Endura
Triple-Stage Quadrupole
Mass Spectrometer**



**Extreme quantitative value
with unprecedented ease**

Thermo
SCIENTIFIC



Unsurpassed value

From forensic toxicology to environmental analysis to pharmaceutical research, a constant in almost every field is the need for greater productivity; to quantify more samples in less time with greater reliability and confidence, and to do it all on ever tighter budgets. The Thermo Scientific™ Endura™ triple-stage quadrupole mass spectrometer meets these needs with unsurpassed value. It delivers best-in-class sensitivity run-after-run and day-after-day regardless of sample type or matrix, and does so with an ease-of-use that takes the worry out of method development and operation.

Best-in-class sensitivity

The TSQ Endura mass spectrometer delivers best-in-class, research-level sensitivity and dynamic range, assuring accurate, reliable quantitation of even low-level or difficult-to-analyze samples.

Unprecedented usability

New software with a simplified user interface makes this next-generation triple quadrupole easier to use. The drag-and-drop method editor speeds method development. Seamless integration with application-specific software ensures maximum productivity.

Ultimate robustness

From an enhanced ion source exhaust port that removes more solvent vapor, to a neutral blocker that keeps the ion optics cleaner, to new electronics that maintain mass accuracy and mass resolution stability, the TSQ Endura mass spectrometer design ensures the same best-in-class performance over hundreds or thousands of samples.



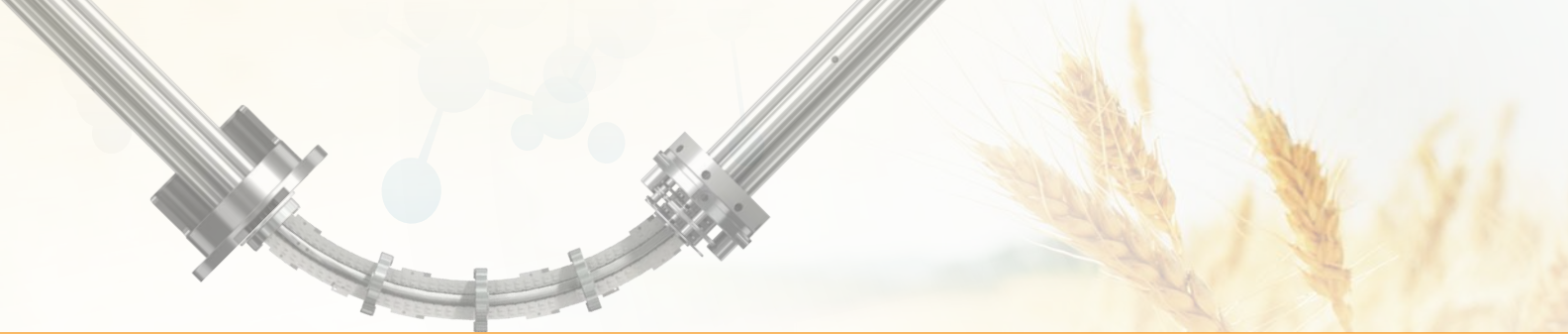

Economical solutions for clinical research and forensic toxicology

Clinical research and forensic toxicology demand fast, accurate, reproducible quantitative analyses...that don't break the budget. The TSQ Endura MS delivers fast, economical quantitation without compromising sensitivity or reproducibility. Simplified methods make operation straightforward for experts and non-experts alike.

Flexible sensitivity for environmental and food safety research

New threats to food safety and the environment emerge every day. The TSQ Endura system makes it easy and practical to keep up with them. A drag-and-drop method editor and close integration with Thermo Scientific™ TraceFinder™ software make development of sensitive, reliable screening and quantitation methods faster and easier than ever before.

Highly productive pharmaceutical research

Pharmaceutical research demands high productivity with uncompromising performance. The high sensitivity and utter reliability of the TSQ Endura MS make it the perfect instrument for the day-in and day-out quantitation of large numbers of pharmaceutical samples. Thermo Scientific™ LCQUAN™ software provides 21 CFR Part 11-compliant data analysis.

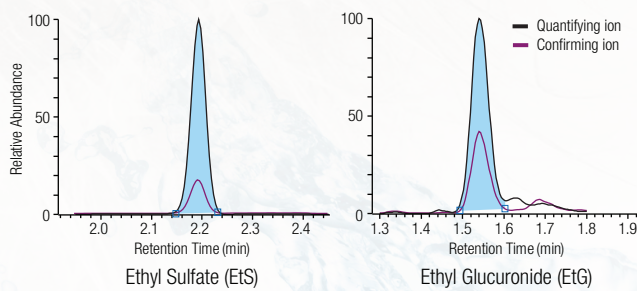

▲ The TSQ Endura system provides sensitive analysis of even difficult-to-analyze samples such as ethyl sulfate and ethyl glucuronide in a urine matrix



Simplified, integrated software delivers performance with ease

Integral to the TSQ Endura system is entirely new software for method development and instrument operation; software that ensures more performance with less effort. The drag-and-drop method editor simplifies method development and close integration with application-specific software packages ensures seamless, effective operation. TSQ Endura software helps researchers focus on their science instead of their instruments while maintaining the highest levels of productivity.

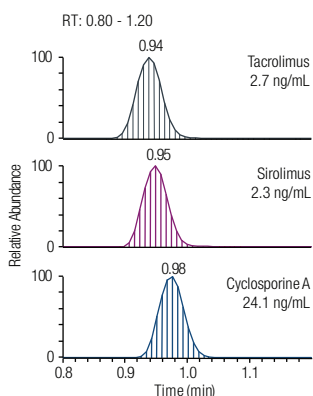

Quantitative analysis of immunosuppressant drugs with the TSQ Endura MS. %RSD for five injections of three different QC samples show excellent precision across a range of concentrations.

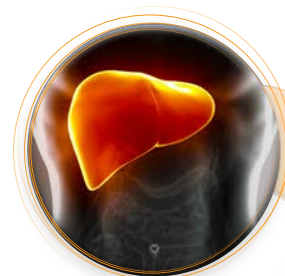
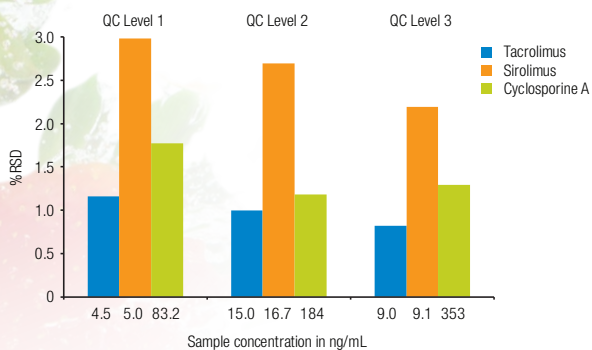

CLINICAL RESEARCH AND FORENSIC TOXICOLOGY

TRACEFINDER SOFTWARE

TraceFinder software provides an extensive database of SRM parameters as well as a set of preconfigured but customizable report templates for environmental, food safety, clinical research, and forensic toxicology applications.



ENVIRONMENT AND FOOD SAFETY



Stability of imipramine (%CV = 5.51%) and maprotiline (%CV = 6.56%) at 1 ng/mL over the course of 221 injections in protein-precipitated plasma, with a single set of integration parameters for all samples

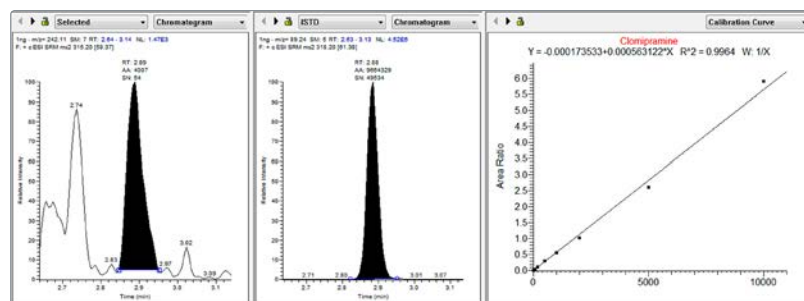
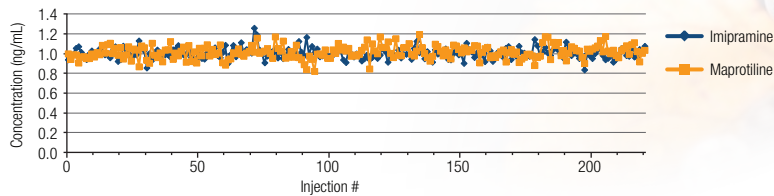

Analysis of clomipramine, a tricyclic antidepressant (TCA), in human plasma at LOQ of 1 ng/mL showing quantifying ion, internal standard ion, and calibration curve

PHARMACEUTICAL ANALYSIS



LCQUAN SOFTWARE
LCQUAN software is a 21 CFR Part 11-compliant solution for method development, data review, processing, reporting, and data export in drug discovery and development experiments.

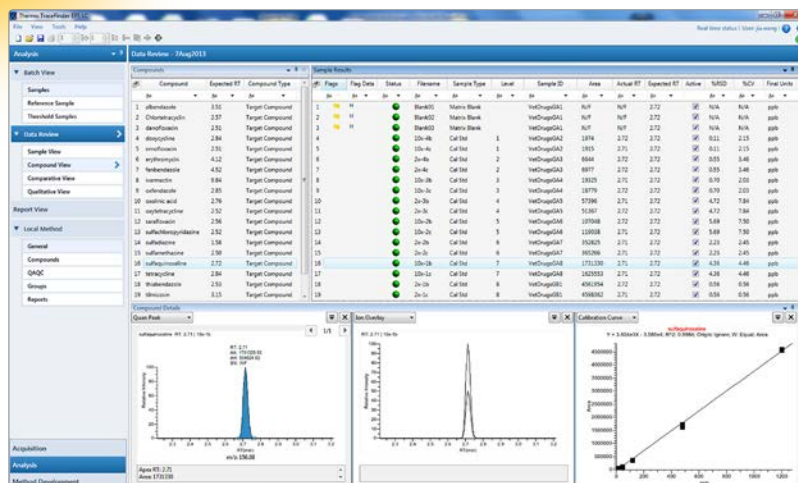

TSQ Endura MS provides sensitive, accurate quantitation of 21 antibiotics with results for sulfaquinoxaline from 0.48 ng/mL to 1200 ng/mL shown here

Innovative design delivers outstanding sensitivity and unsurpassed robustness

REDUCED NOISE

Curved ion beam guide stops neutrals and high-velocity clusters with a neutral blocker, keeping the ion optics cleaner, reducing noise, and increasing sensitivity.

ENHANCED SENSITIVITY

RF-Lens captures and focuses the cloud of ions exiting the capillary and efficiently transfers them into the ion beam guide for enhanced sensitivity.

MORE ROBUST OPERATION

An enhanced exhaust port with constant nitrogen flush removes more solvent vapor, reducing baseline noise and increasing uptime.

EASIER TO USE

EASY-Max NG ion source makes all gas and electrical connections automatically on installation. It accommodates HESI, APCI, and combined HESI/APCI probes, which can be swapped quickly, without tools.

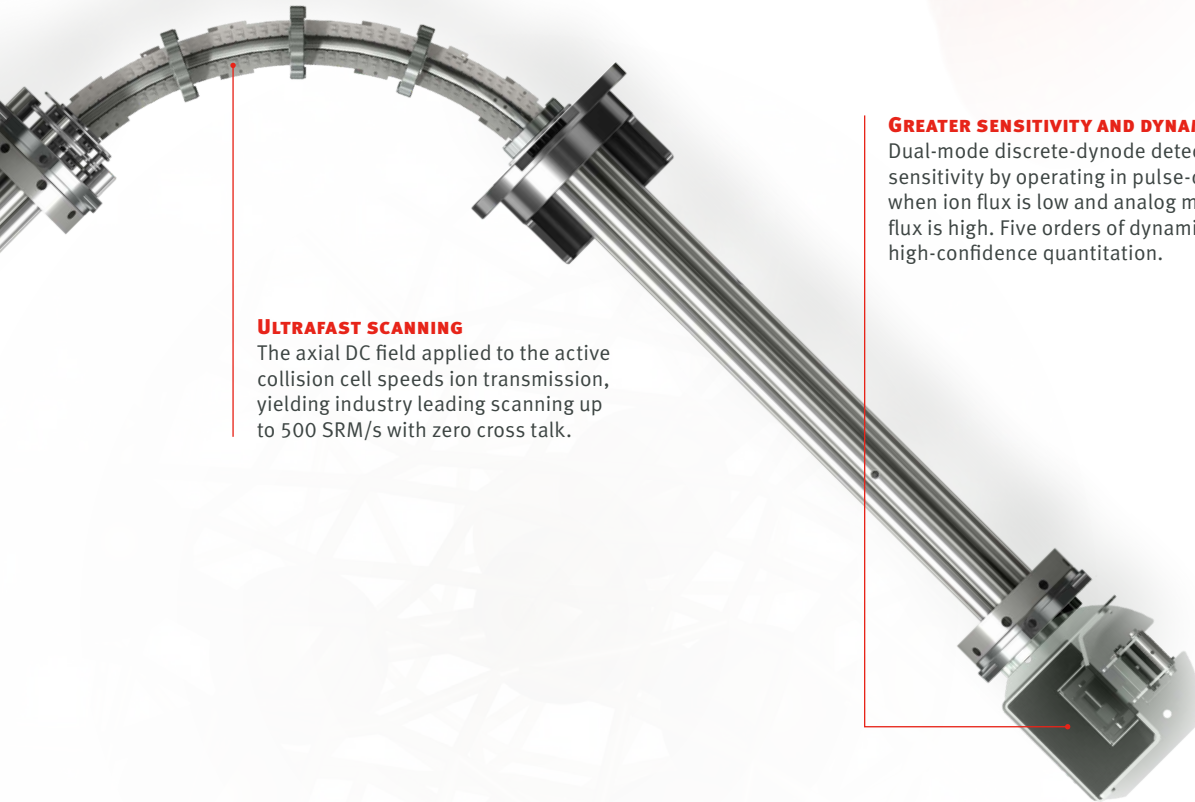

ULTRAFAST SCANNING

The axial DC field applied to the active collision cell speeds ion transmission, yielding industry leading scanning up to 500 SRM/s with zero cross talk.

GREATER SENSITIVITY AND DYNAMIC RANGE

Dual-mode discrete-dynode detector increases sensitivity by operating in pulse-counting mode when ion flux is low and analog mode when ion flux is high. Five orders of dynamic range provide high-confidence quantitation.

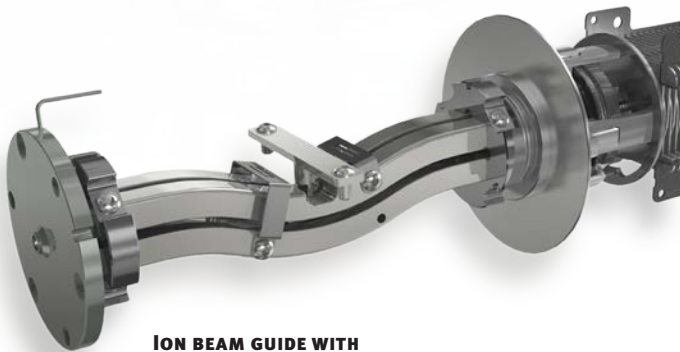

ION BEAM GUIDE WITH NEUTRAL BLOCKER

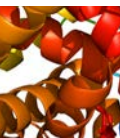

Transforming science with the next generation of mass spectrometers

The TSQ Endura mass spectrometer is just one of a family of transformational, next-generation Thermo Scientific mass spectrometers that combine unprecedented performance and usability. Others include:

- Thermo Scientific™ TSQ Quantiva™ triple-stage quadrupole mass spectrometer
- Thermo Scientific™ Orbitrap Fusion™ Tribrid™ mass spectrometer

These next-generation instruments are built on a foundation of shared, state-of-the-art hardware and software components. This commonality makes it easier to transfer methods from one instrument to another when research progresses from single-sample-based experiments to validation and high-volume screening or routine quantification.



All of these Thermo Scientific mass spectrometers can be paired with a range of high-performance Thermo Scientific LC systems. Regardless of application, there is an LC that will ensure the highest possible performance.



For Research Use Only. Not for use in diagnostic procedures.

www.thermoscientific.com

©2013 Thermo Fisher Scientific Inc. All rights reserved. ISO is a trademark of the International Standards Organization. All other trademarks are the property of Thermo Fisher Scientific Inc. and its subsidiaries. Specifications, terms and pricing are subject to change. Not all products are available in all countries. Please consult your local sales representative for details.



Thermo Fisher Scientific,
San Jose, CA USA is
ISO 9001:2008 Certified.

Africa-Other +27 11 570 1840
Australia +61 3 9757 4300
Austria +43 810 282 206
Belgium +32 53 73 42 41
Canada +1 800 530 8447
China +86 10 8419 3588
Denmark +45 70 23 62 60

Europe-Other +43 1 333 50 34 0
Finland +358 9 3291 0200
France +33 1 60 92 48 00
Germany +49 6103 408 1014
India +91 22 6742 9494
Italy +39 02 950 591
Japan +81 45 453 9100

Latin America +1 561 688 8700
Middle East +43 1 333 50 34 0
Netherlands +31 76 579 55 55
New Zealand +64 9 980 6700
Norway +46 8 556 468 00
Russia/CIS +43 1 333 50 34 0
South Africa +27 11 570 1840

Spain +34 914 845 965
Sweden +46 8 556 468 00
Switzerland +41 61 716 77 00
UK +44 1442 233555
USA +1 800 532 4752

BR63843_E 09/13

Thermo
SCIENTIFIC

Part of Thermo Fisher Scientific